

FULLY AUTOMATIC NECK TAG PROMO APPLICATOR

Features:

- Designed to “push” into existing line
- Can be fitted with Auto-interchange
- Tag placement of +/- 1mm
- Self contained operation
- No stopping to change rolls
- Fast package change-over
- Operator interface/touch-screen
- Designed to fit in new or existing line
- Orientation available
- Can be moved from one line to another

Specifications:

PLC:	Mitsubishi
Power:	220v /Single Phase/ 20amp
Web Speed:	0-50 Linear Meters
Label Drive:	AC Servo closed loop
Positioning:	AC Servo closed loop
Execution:	Left or Right
Frame:	Stainless/Aluminum
Tag Size size:	As specified by client
Application speed:	Up to 300 per min



Sole Agents for Impresstik and Reeltek Systems
Offices in California, Oregon, British Columbia
Coast to coast coverage

Ph: 707 291 2803

www.tapptech.com

aobrien@tapptech.com



OPERATOR INTERFACE/TOUCH-SCREEN

- Link to PLC
- Available in Different languages
- Located on a Swivel arm for easy access
- Analogue reference to control all AC motors
- Mitsubishi standard or as specified
- Change settings “on-the-fly”

FEEDSCREW ASSEMBLY

- Positive product separation
- Controlled through Operator Interface/Touch-screen
- Quick change system

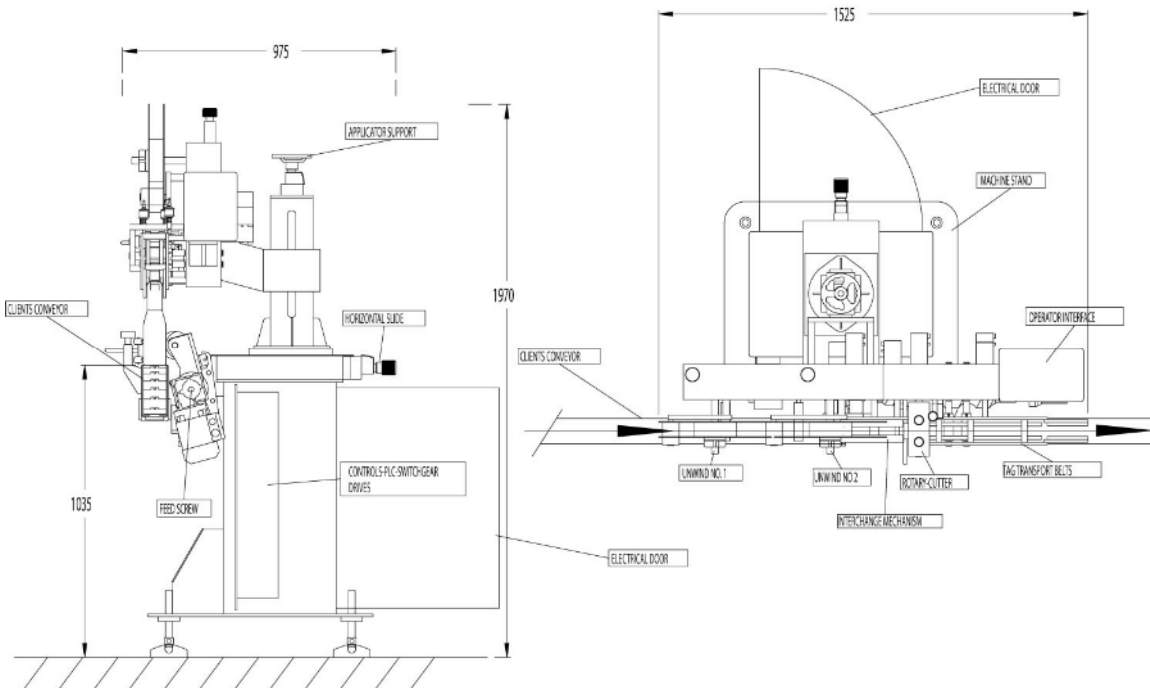

The Reeltek Protag® System is ideal for product promotions. Tags can be formatted as single ply or folded formats and printed on all sides. Various tag sizes are available. The machine is designed to be easily moved from one bottling line to another.

www.tapptech.com

Sole Agents for Impresstik® and Reeltek Systems®
aobrien@tapptech.com